

SPACE BASIC™

Multipurpose cabinet | Armoire de rangement multifonctions | Vielzweckschrank | Armario multiuso | Armadio Multifunzione | Multifunctionele kast | Armário de várias finalidades | Ντουλαπα Πολλων Χρησεων

Assembly Instructions | Instructions de Montage |
Montageanleitung | Instrucciones de Montaje |
Istruzioni di Montaggio | Montagevoorschrift |
Instruções De Montagem | Οδηγισ Συναρμολογησις

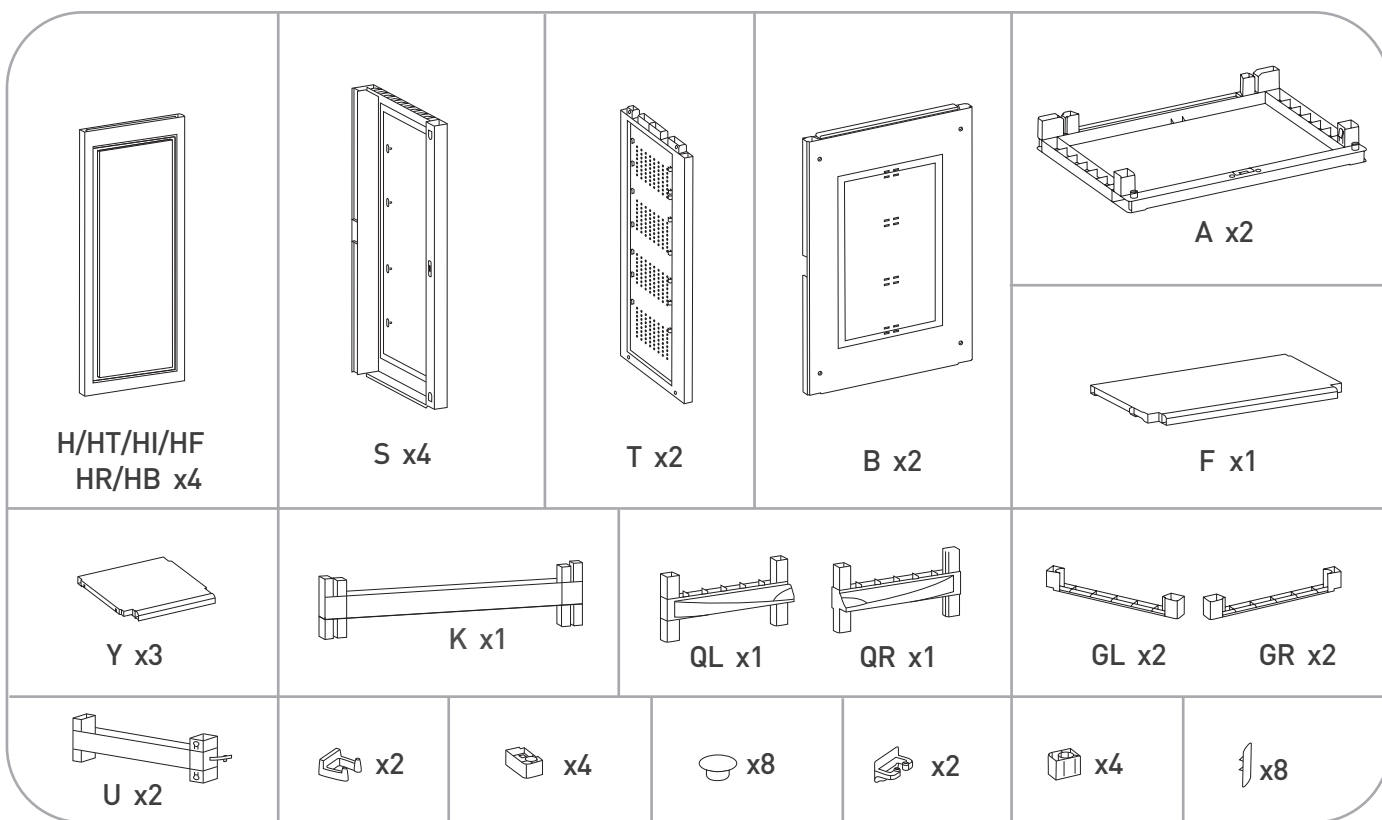

IMPORTANT: Please contact Customer Service if you have any problems or discover any missing parts.

IMPORTANT: Veuillez contacter notre Service Clientèle pour tout problème ou pièce manquante.

WICHTIG: Bitte wenden Sie sich an unseren Kundenservice, falls Sie irgendwelche Probleme haben oder feststellen, daß Teile fehlen.

IMPORTANTE: Sírvase contactar con nuestro Servicio al Cliente por cualquier problema, o pieza que pudiera faltar.

IMPORTANTE: Si prega di contattare il Servizio Clienti per eventuali necessità

BELANGRIJK: Neemt u in geval van problemen of missende onderdelen a.u.b. contact op met de klantenservice.

IMPORTANTE: favor entrar em contato com o Serviço ao Cliente se houver problemas ou se faltar peças.

ΣΗΜΑΝΤΙΚΟ: παρακαλώ επικοινωνήστε με την Εξυπηρέτηση Πελατών αν αντιμετωπίσετε κάποιο πρόβλημα ή αν λείπει μέρος από την συσκευασία

USA

Call Toll Free Number: 1-(888)-374-4262

Canada

Appel gratuit / Call Toll Free Number:
1-800-661-6721

United Kingdom:

Keter (UK) Ltd.
Unit 4, Woodgate Business Park, Clapgate Lane,
Birmingham, B32 - 3DB, United Kingdom.
Tel: 0121-5060008, Fax: 0121-4220808

Other European Countries:

Keter Europe Gardening
Ericssonstraat 17, Postbus 224,
5120 AE Rijen, the Netherlands. Tel: 31-1612-28301, Fax: 31-1612-28322
PRIMATRONIC S.R.L. Via L. Da Vinci, 281
20090 Trezzano s/N (MI) Italia
Tel. + 39 02 4478086 / + 39 02 4451241, Fax +39 02 4478151

1

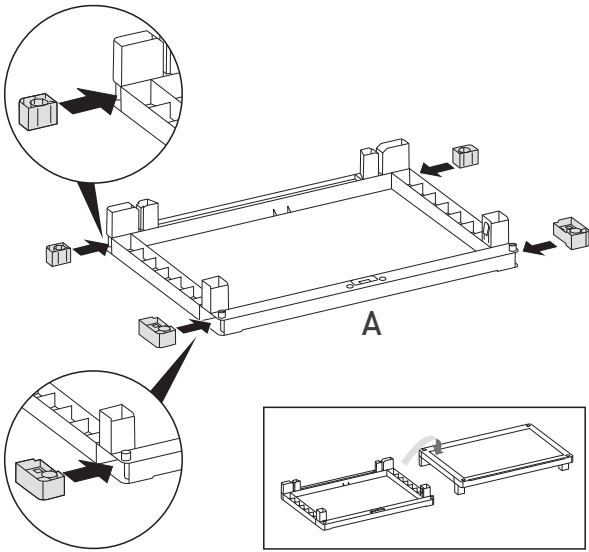

x2

2

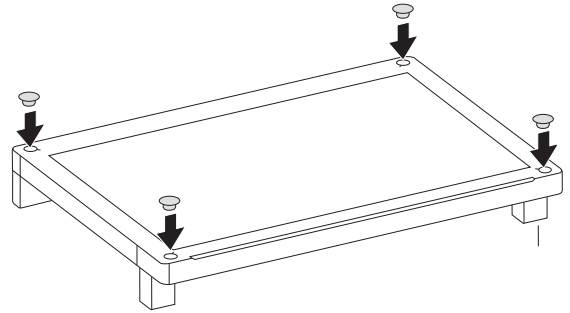

x2

3

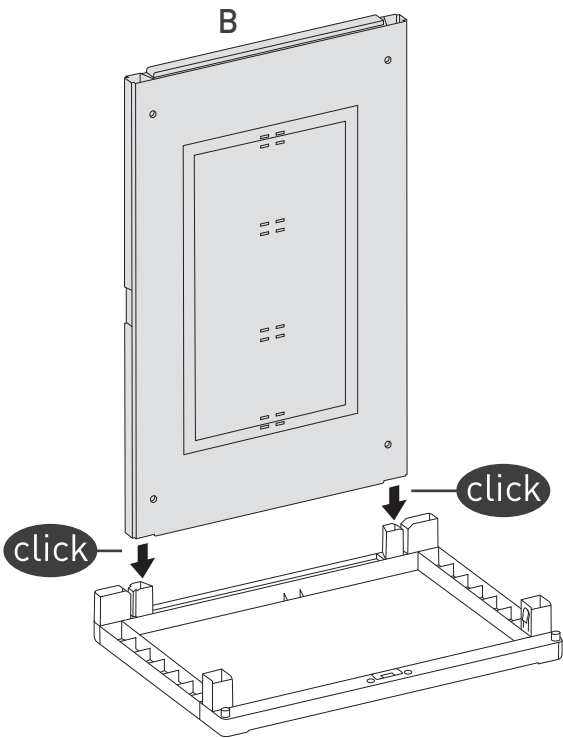

4

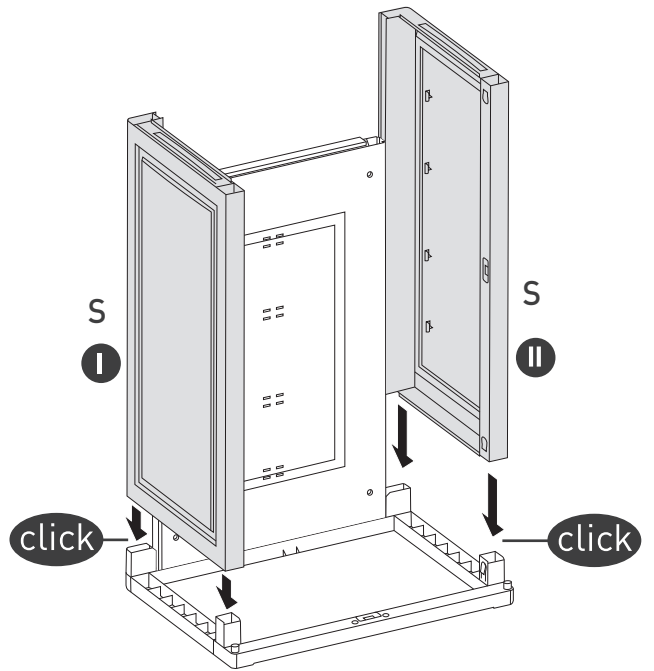

5

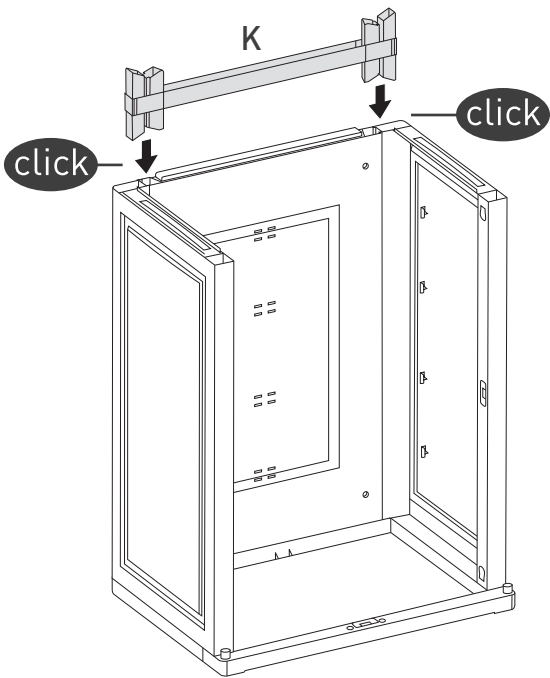

6

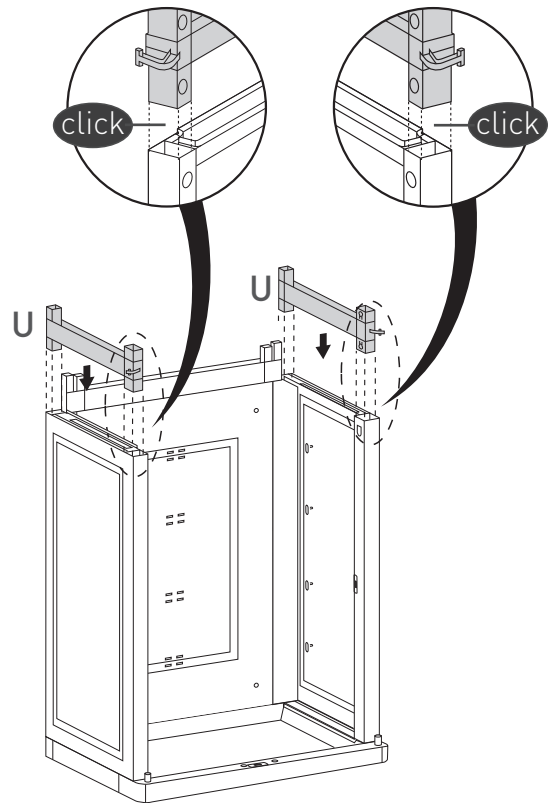

7

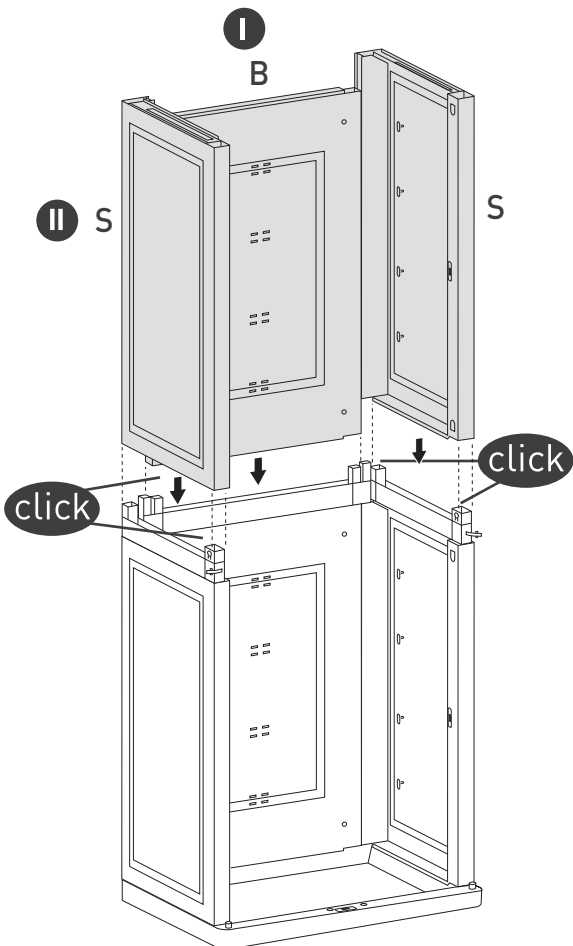

8



Leave open | Laissez ouvert | Offen lassen |
Dejar abierto | Lasciare aperto | Openlaten |
Pozostawi otwarte | Αφήστε Το Ανοιχτό

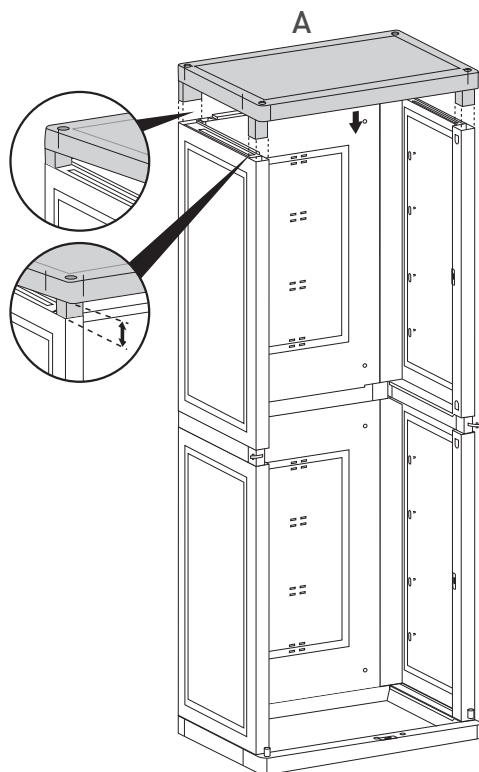

9

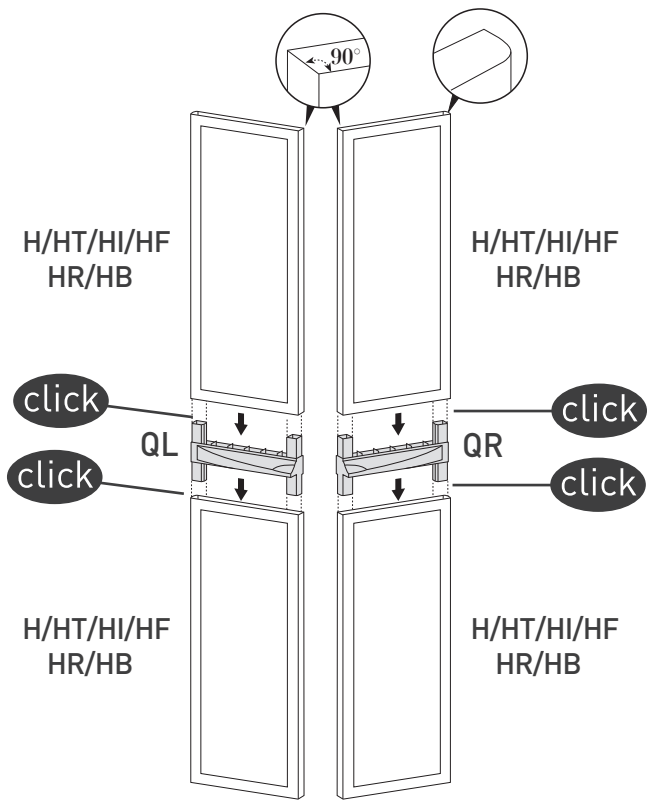

10

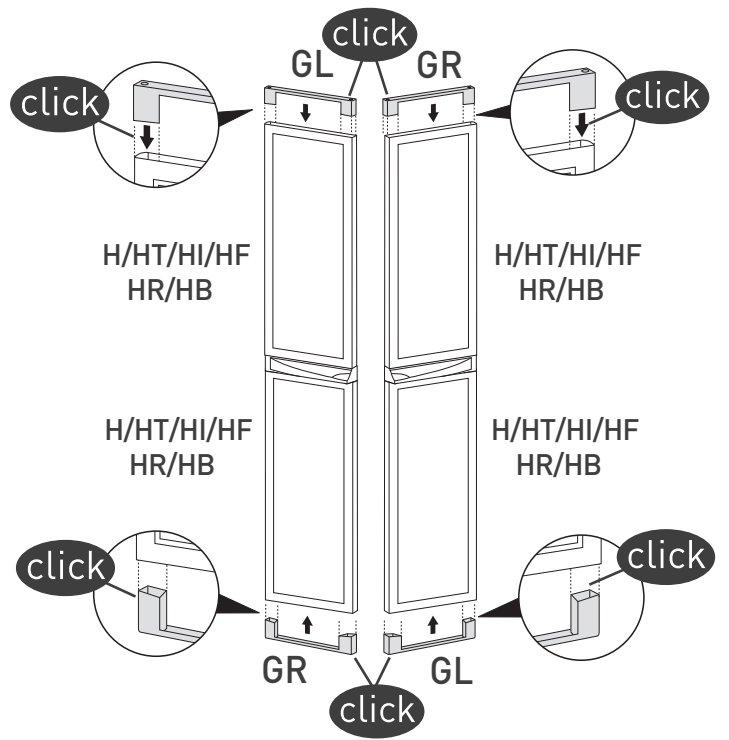

11

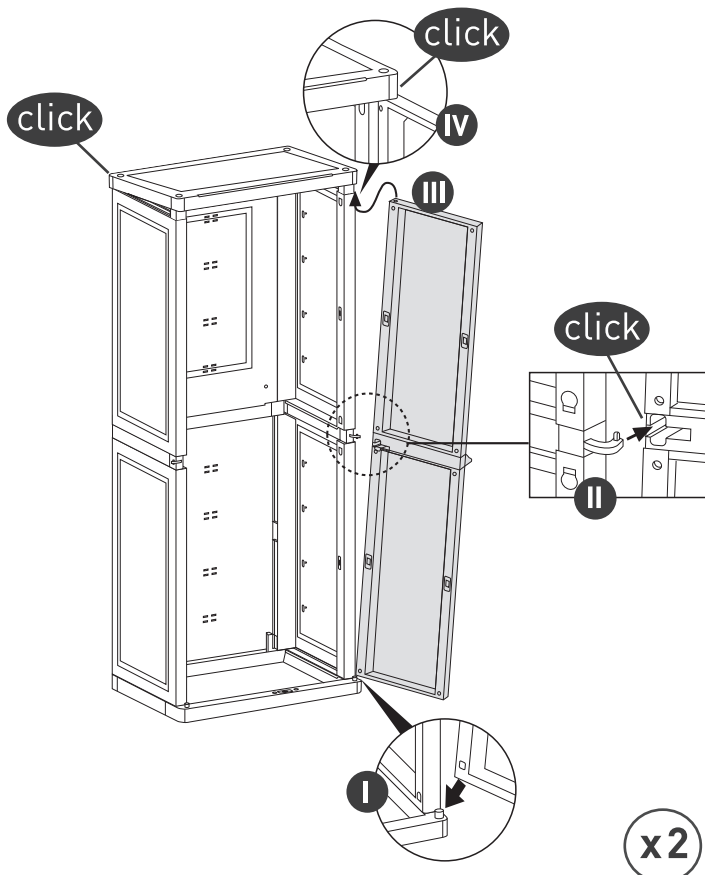

12

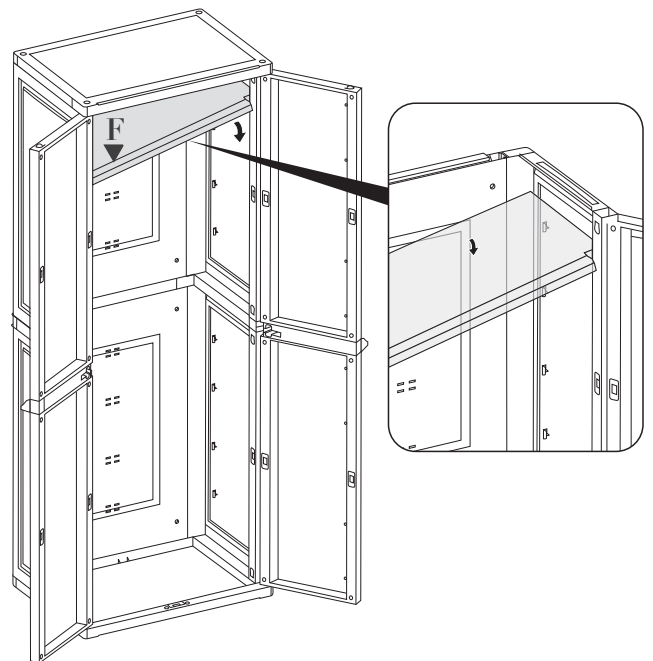

13

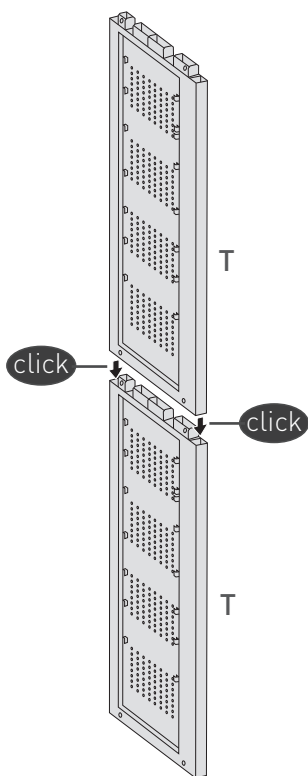

14

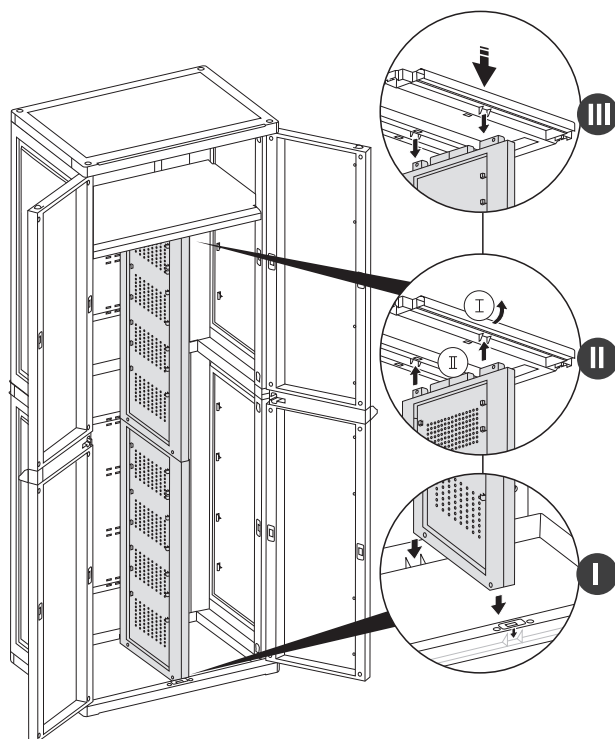

15

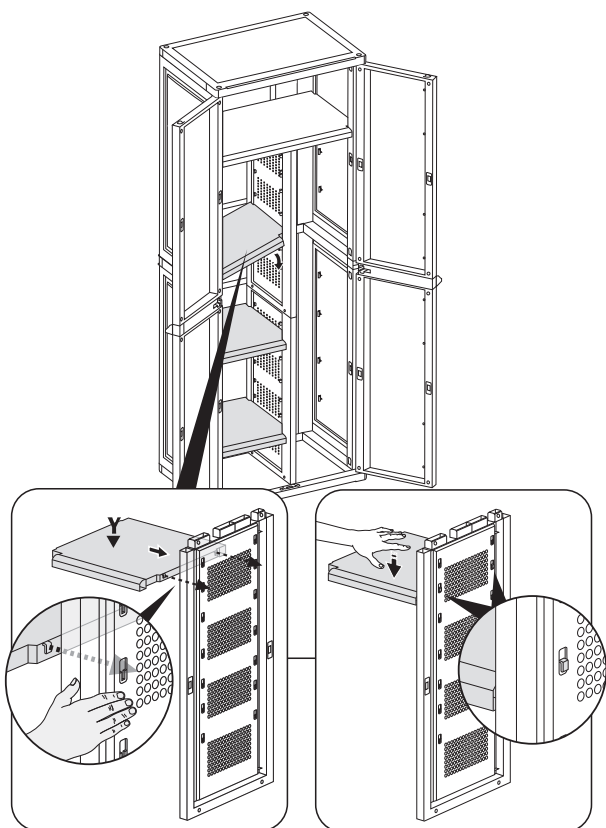

16

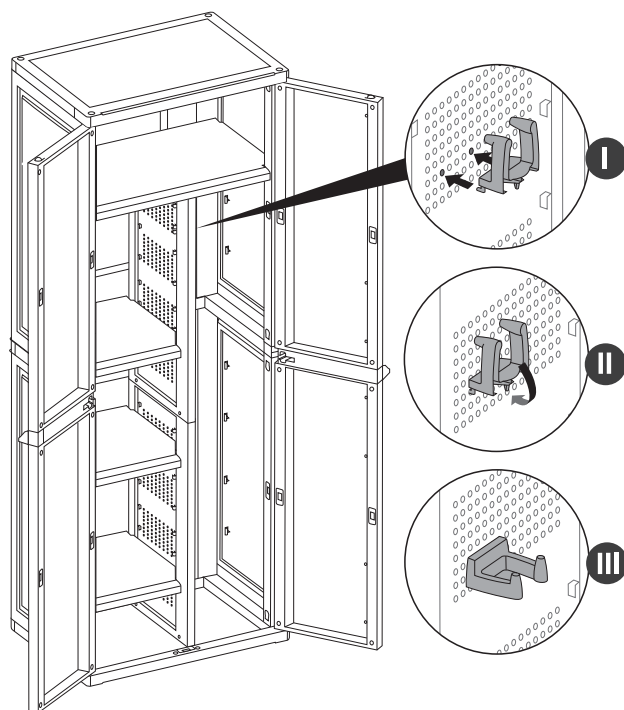

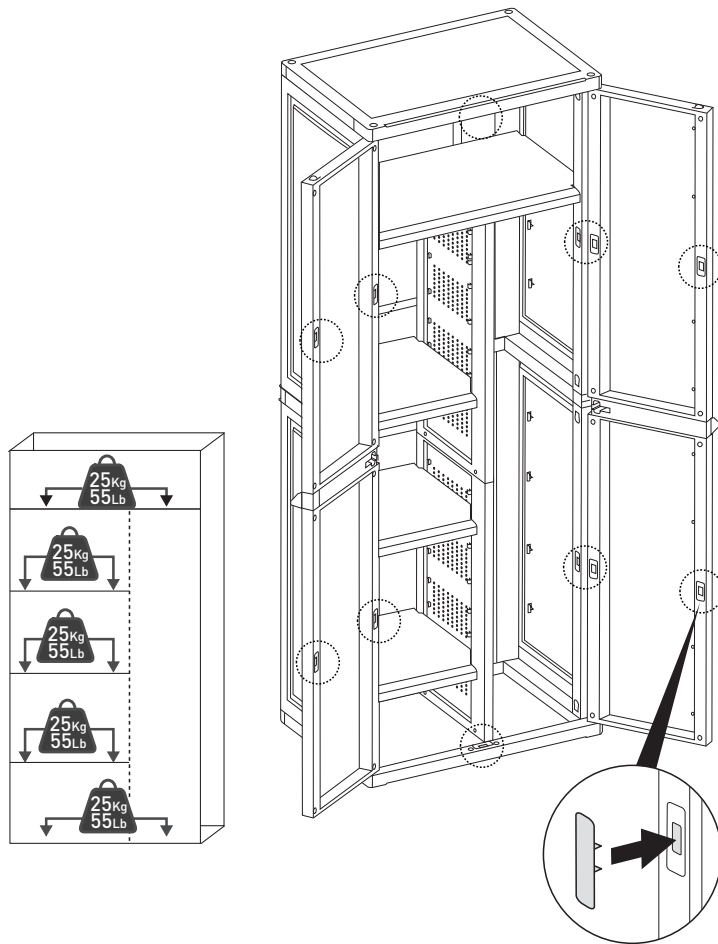

After assembly is completed there may be extra small parts, you may dispose of these as they are not needed | Une fois l'assemblage terminé, il se peut que vous ayez quelques petites pièces en trop dont vous pouvez vous débarrasser car elles ne sont pas nécessaires | Sollten nach dem Zusammenbau kleinere Plastikteile übrig geblieben sein, so können Sie diese entsorgen | Finalizado el montaje, pueden sobrar algunas piezas, puede disponer de ellas pues no son necesarias | A montaggio ultimato possono avanzare alcune piccole parti, queste possono essere smaltite perchè non sono necessarie | Voor de zekerheid zijn extra kleine onderdelen toegevoegd, de onderdelen die teveel zijn ontvangen mag u weggooien bij uw huisafval | Concluído a assembléia, eles podem ter alguns pedaços mais que suficiente, pode os ter porque eles não são necessários | Όταν η συναρμολόγηση έχει ολοκληρωθεί μπορεί να υπάρχουν επιπλέον μικρά κομμάτια που δεν χρειάζονται, μπορείτε να τα διαθέσετε στα άχρηστα |